

Building a Bat House

Wisconsin Bat Program
Natural Heritage Conservation



Wisconsin Department of Natural Resources
<http://dnr.wi.gov>
<http://wiatri.net/inventory/bats>

WISCONSIN
BAT PROGRAM 

Building a Bat House



Why Build a House?

Many people do not want bats roosting in their homes, but often still want bats around. What's a good way to encourage bats to remain in the area before they have been excluded from homes? Build a bat house!

Bats are an integral part of the ecosystem and can act as organic pest control. Encouraging bats to take up habitation on your property can help reduce forest and garden as well as human-disease carrying pest populations. Bats have voracious appetites, and a single bat can eat thousands of insects every night.

Building a bat house is a great way to help these threatened animals. Because of their slow reproductive rates and longevity, bats of all species are at risk of population decline. Habitat loss, pesticides and an invasive fungus that is associated with White-Nose Syndrome are all negatively impacting bat populations. Providing alternative roosting habitat with your bat house can help lessen the impacts of these threats. While you're creating habitat, you can also contribute to monitoring of bat health and status. Little is known about bats in general, and any information about them can provide knowledge about how to help conserve bats.

Once you've built your bat house, identified suitable habitat to install it, and it is successfully inhabited, join WDNR's roost monitoring project. Through this project you can let bat researchers know about what kinds of bats inhabit your bat house, and how many bats you get each year. You can also report on the best methods and locations for encouraging bats to occupy your bat house.

There are no known methods for attracting bats; you can only encourage them by creating suitable roosting habitat. Following the instructions in this handbook on building, placement and upkeep will help you increase your chances of having bats roost in your bat house and encourage them to return year after year.

Building a Bat House

Building Instructions

This guide gives you information about what supplies and materials to use and where to get them. It also includes instructions on key specifications for the bat house such as bat house design, location and mounting. Wisconsin's bats have preferred habitats, and you may be able to tailor the specifications of your bat house to encourage one species or another.

Bat House Design

In order for a bat house to successfully encourage bats to reside in your roost, research has shown that a few key characteristics are necessary while choosing a design for your bat house.

- The most successful bat houses are at least two feet tall, 14 or more inches wide, and are open at the bottom. The opening prevents buildup of guano and parasites, and lessens the need for routine cleaning.

- Bats will use both single- and multi-chambered bat houses; however a multi-chamber house improves the ability of the bats to regulate their temperature. A single chamber bat house will often not accumulate large numbers of bats that multiple chambered houses. When building a multiple chambered house, make sure there is space on top of the baffles for the bats to move around the house and regulate their temperature.

- Make sure the interior wood is sufficiently rough for the bats to hang on. Wood that is too smooth may cause the bats to slip and fall. Avoid using a plastic or wire mesh: The mesh and staples can degrade over time and start peeling off the bat house. This can trap and entangle bats. Wire mesh is too sharp and may tear the wings.

- Bats need a "landing pad" on the bottom of the bat house. Build your bat house so that approximately 4 inches of roughened wood extends from the bottom on the back of the bat house. This allows the bats to land and climb up into their roosting chamber.

- Add a vent to each side and a small slit vent to the front of the house to allow air flow. This prevents the bat house from overheating.

- Bats don't like drafty homes, so when building your bat house, it is crucial that you caulk all seams to prevent water as well as cold and warm air drafts from entering the structure.

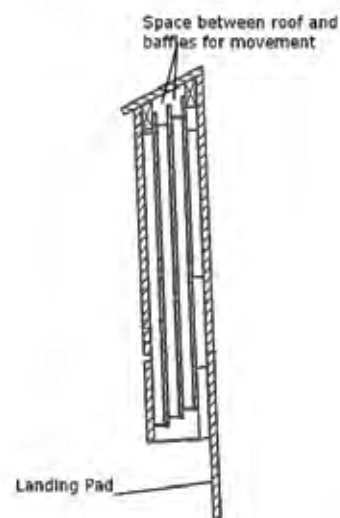

Interior of a maternity bat house

Building a Bat House

- Included in this handbook are several simple designs for bat houses. For additional information, **Bat Conservation International** offers a **Bat House Builder's Handbook** with additional designs and advice.

What Materials to Use and Where to Get Them

Bat houses can be built of very simple materials.

- The best wood to use to build your bat house is naturally weather resistant wood like cedar, rough-sawn black locust, white oak or old barn wood. These still need to be treated with paint on the outside, but the wood will last much longer than softer wood such as pine or plywood.
- As a last resort, half-inch exterior grade plywood can be used for the front and back and one-inch for the sides. Do not use treated lumber as it often contains chemicals that are toxic to bats.
- Avoid using recycled materials as they might have been treated, and can also be toxic to bats. Avoid Kilz® primer, as bats tend to avoid it.
- Common building materials and tools will be needed such as screws, drill, table saw, utility knife, clamps and measuring tape.
- Grooves should be added horizontally every 1/4 to 1/2 inch on interior wood surfaces to allow the bats to hang. Grooves should be 1/4 mm to 1/2 mm deep. Use a utility knife to score the surface.
- Wood treatment supplies: Because of Wisconsin's climate, a coat of primer followed by a coat of dark (dark brown or black), non-toxic, water-based exterior paint or stain should be added to the outside of the box to prevent deterioration, and help it heat up during the day.
- Use non-toxic, paintable, exterior-grade caulk on all seams to prevent water and drafty air from getting into the bat house. Latex caulk is easiest to use. Caulking helps the bat house retain heat and also prevents warping and future leaks.
- Note that if using cedar, the boards are usually thicker and require either reducing the number of baffles or making the bat house wider to accommodate the thicker wood.

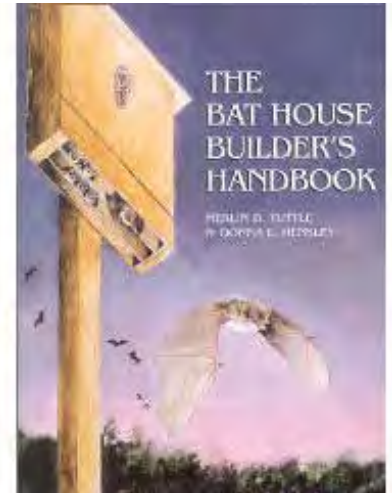

Building a Bat House

Tailoring Your Bat House to Specific Species

Wisconsin has four species of bats that may roost in your bat house: the little brown bat, the big brown bat, the Eastern pipistrelle and the Northern long-eared bat. The first two species are far more likely to be found roosting in bat houses than the latter two.

If you were considering putting up multiple bat houses around your property, you may want paint one house a dark color and leave the other a lighter color. Big brown bats tend to like cooler temperatures than Little brown bats so leaving one bat house a lighter color would ensure a cooler roosting environment. Having multiple houses also allows bats to shift roosts depending on temperature changes throughout the summer. In order to encourage nursery colonies to roost in a bat house, the house must be large enough to accommodate many individuals. Make your bat house about 24 inches to make it preferable to large quantities of bats.



Kent Borcharding with bat houses he built for Stonefield Historic Site in southwestern Wisconsin

Where to Put Your Bat House

Where you place your bat house is the most important factor determining how successful you are at encouraging bats to use the site.

- Bats like it hot (90 F°-100 F°), so put your bat house where it will receive large amounts of sunlight. Orientate the house in a south to southeast facing direction to capture as much mid-day sun as possible. Six hours of direct sunlight a day is ideal. If two bat houses are being installed back to back, place one facing south and one facing north or one facing east and one west to allow for varying temperatures.
- Bats are associated with water, especially maternity colonies, so putting your bat house within a quarter mile of a water source such as creek, pond, river, lake or stream, is a great way to encourage bats to take up residence.
- The best habitat for many species contains lots of diversity. Place your bat house in an area with a mixed agriculture/forest/urban landscape.
- Mount your bat house away from trees to discourage predation and allow for flyways. Place it about 10-15 feet away from trees, but keep it sheltered from winds. Do not place on top of a hill where it may be subject to excessive winds.
- Reduce tall vegetation (shrubs and bushes) below the base of your bat house.

Building a Bat House

Mounting Your Bat House

The best place to mount a bat house is on a tall pole, or on the side of a building.

- Bat houses on the side of a building heat up more quickly than those on poles.
- Mount boxes anywhere from 8 to 20 feet above the ground.
- Avoid mounting the box on a tree because tree locations are too shaded, and allow predators to easily prey on the bats in the box.
- Avoid shiny objects underneath the roost (on the ground). If you want to collect guano for your garden, use a non-reflective tray.
- Two houses can also be mounted back to back on a pole, and the space in between can be used as a roost.

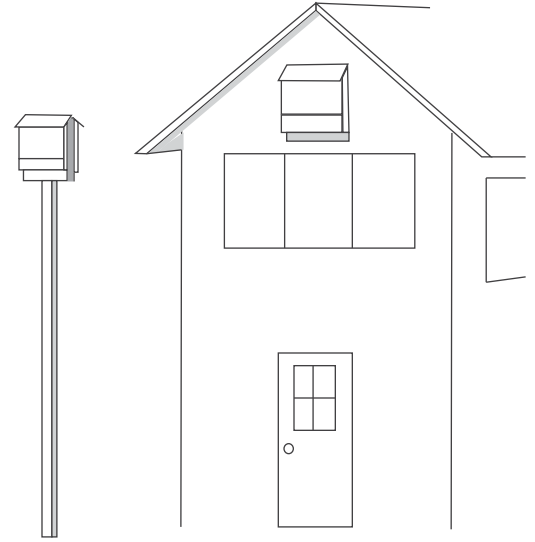

Possible mounting options for bat houses. Eaves can trap heat in the evening and help buffer temperature swings overnight.

Yearly Maintenance

A bat house that is built correctly requires minimal maintenance, but should be checked yearly for any problems or unwanted guests.

- Any maintenance should be done in the months when bats are not present (November to early March). Check for any cracks, warps, leaks or exposed unpainted wood on the house, that may need minor repairs.
- Make sure you don't have any unwanted guests like paper wasps or mud daubers. If you find them, use a stick or pole to scrape the nest out of the box.
- Check for any buildup of guano and clean it out with a stick or pole.

Collecting Data on Your Bat Residents

You've now successfully built and mounted your bat house. The information you can gather from your bat house will provide critical long term monitoring data for bat studies in the state. Wisconsin Department of Natural Resources has created a bat roost monitoring program throughout the state. To join in the advancement of our knowledge of Wisconsin bats, contact Wisconsin DNR bat monitoring program and sign up today. Roost monitoring entails counting bats as they exit your bat roost just a few times per year.

For more information on monitoring: dnrbats@wisconsin.gov

Building a Bat House

The Health of You and the Bats

As you observe the bats inhabiting your bat houses, keep in mind the safety of both you and the bats living in your bat house. When observing the bats, limit your disturbance; avoid shining bright flashlights into the house to count them, and do not attempt to move the bat house once it has bats living in it.

Sometimes people get colonies of bats that live in their attics or other buildings. When young bats start to fly on their own in mid-to-late summer, they can sometimes get lost and find their way into your living space. If this happens, wait for the bat to land, and use a shoebox to cover the bat and release it outside. You can also open a window, close the room off and wait for the bat to leave on its own. ***Never use your bare hands to pick up a bat because it may bite to defend itself.*** If it is absolutely necessary to pick up a bat, always use leather gloves.

While rare, there are several diseases that may be transmitted by bats, and should be kept in mind when entertaining your bat guests.

Rabies: Although the incidence of rabies in bats is low (less than 0.5%), you should still take precautions if you find a bat flying during the day, or see other abnormal behavior from a bat. If you wake to find a bat flying in your room, or if you find a bat flying in someone else's room while they are sleeping, it is best to get the bat tested to make sure that if bitten, the person will not contract rabies. See CDC recommendations at

- <http://www.cdc.gov/rabies/bats/index.html>

Histoplasmosis: Histoplasmosis is caused by a fungus which grows best on organic matter such as bat guano in warm wet conditions. The fungus causes a respiratory infection, but is rarely fatal if left untreated. Symptoms of Histoplasmosis are often flu-like with fever, cough and fatigue. In Wisconsin Histoplasmosis may be contracted in places like attics where many bats roost, and there is little airflow. Avoid areas where there are large accumulations of bat guano, but if you must enter such as area, use a respirator and other protective equipment to prevent contraction of the disease. The accumulations of guano that occur under your bat houses are unlikely to contain the fungus that causes Histoplasmosis.

WDNR's bat monitoring program also keeps track of dead and sick bats. If you see either dead or sick bats, visit the Wisconsin bat monitoring website to report the occurrence.

- <https://www.cdc.gov/fungal/diseases/histoplasmosis/index.html>

Organize a Bat House Building Party

You will be able to produce many more bat houses if you create a system that mass produces different parts of the bat house. Plus it's fun to work with family and friends.

Donate extra bat houses to friends, family and places like nature centers and schools or sell the remaining houses as a fundraiser for your local group.



Building a Bat House



Can't Get Bats to Live in Your Bat House?

There are multiple reasons why a bat house doesn't have bats living in it, although it may take up to 2 to 3 years for bats to start roosting in your bat house. Have patience before you consider moving it. For information on common problems see Bat Conservation and Management's website at:

<http://www.batmanagement.com/Batcentral/batboxes/whyfail.html>

Useful Websites:

Wisconsin Bat Program Website: <http://wiatri.net/inventory/bats>

- Bat house building video: <https://dnr.wi.gov/topic/wildlifehabitat/bathouse.html>

Bat Conservation International: www.batcon.org

USFWS White-nose Syndrome: <http://whitenosesyndrome.org>

References

Information for this handbook was adapted from:

Tuttle, M. D., D. L. Hensley. The Bat House Builder's Handbook. Austin: University of Texas Press, 1994. 34 Pp.

Discussions with Kent Borcharding, Hazel Green, Wisconsin



Building a Bat House

Single Chamber Bat Box

Materials Needed:

See Diagram for Measurements

One lb. 1 5/8" coated deck or exterior grade screws

20-25 1 1/4" coated deck or exterior grade screws

One quart black, water-based stain, exterior grade

One quart water-based primer, exterior grade

One quart flat water based paint or stain, exterior grade

One tube of paintable exterior grade caulk

One 1" x 2" x 8' (3/4" x 1 3/4" finished) cedar or pine furring strip for spacers

Suggested Wood

We suggest using rough-sawed black locust, white oak, cedar or old barn wood because the bat house will last longer using these naturally decay-resistant materials

Optional Materials

Black asphalt shingles

Roofing nails

1 sheet (4x4) exterior grade plywood

Recommended tools

Drill (1/8" size for pilot holes)

Table saw

Drill bit

Paint brush

Caulk gun

Utility knife

Tape measure

Construction Procedure:

1. Mark wood and cut out all parts as per diagrams on pages 10.

2. Roughen interior and landing surfaces (B) with a utility knife, cutting horizontal lines 1/2" apart, 1/16" to 1/32" deep on the back wall.

3. Apply 2 coats of black, water-based stain to interior surfaces. Do not use paint as it will fill the grooves.

4. Drill pilot holes and screw back (B) to side and top spacers, caulking wherever wood meets wood.
5. Drill pilot holes and screw front (A) to sides and top spacers. Again, caulking all seams.
6. Caulk, then drill pilot holes and screw roof (C) to front (A), back (B) and side and top spacers.
7. Sand if necessary to make sure angles match.
8. Use a utility knife to cut a line on underside of roof to act as a drip edge
9. Attach mounts to back of box, making sure there is 1/2-3/4" between the box and the mounts using spacers
10. Prime the exterior of the house
11. Paint the exterior with 2 coats of paint. Stain the landing pad on back wall (B) to make sure no paint fills the grooves.



Single chamber box on left

Building a Bat House

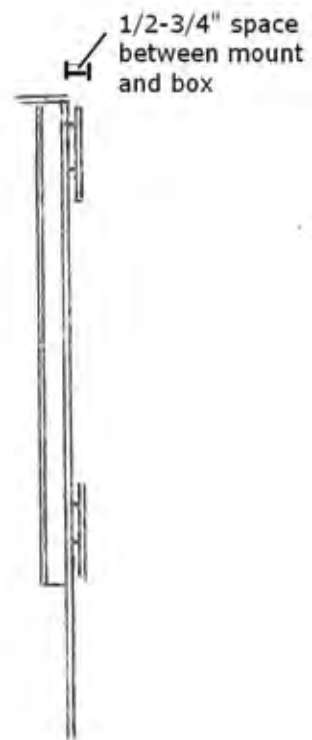
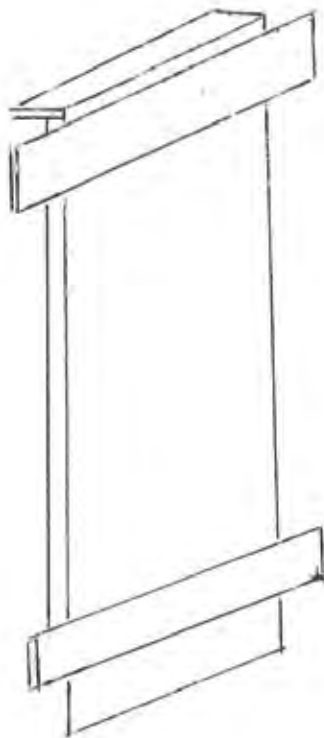
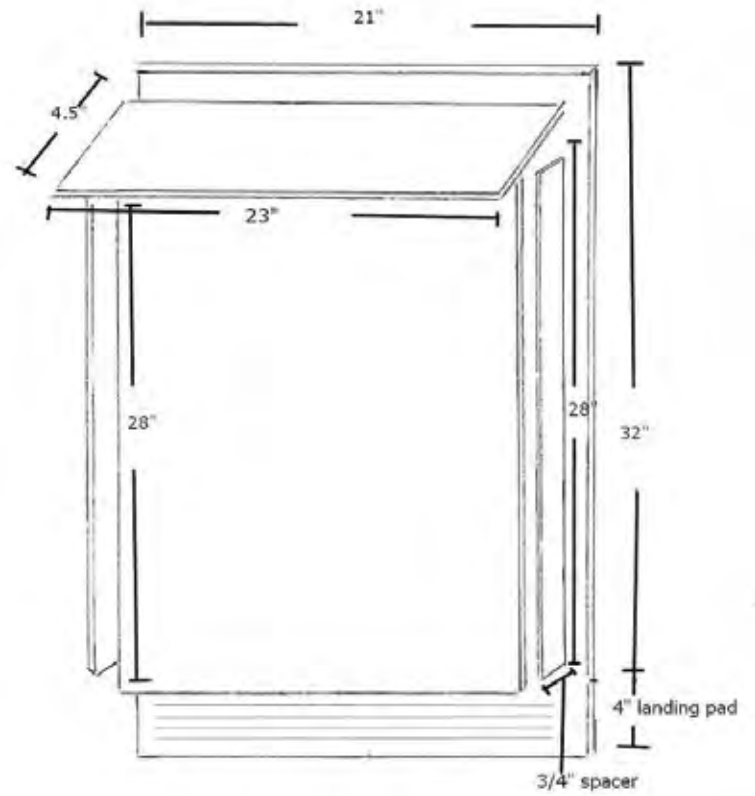

Building a Bat House

If decay-resistant wood such as cedar or black locust is not available, a 4' x 4' piece of exterior-grade plywood may be used

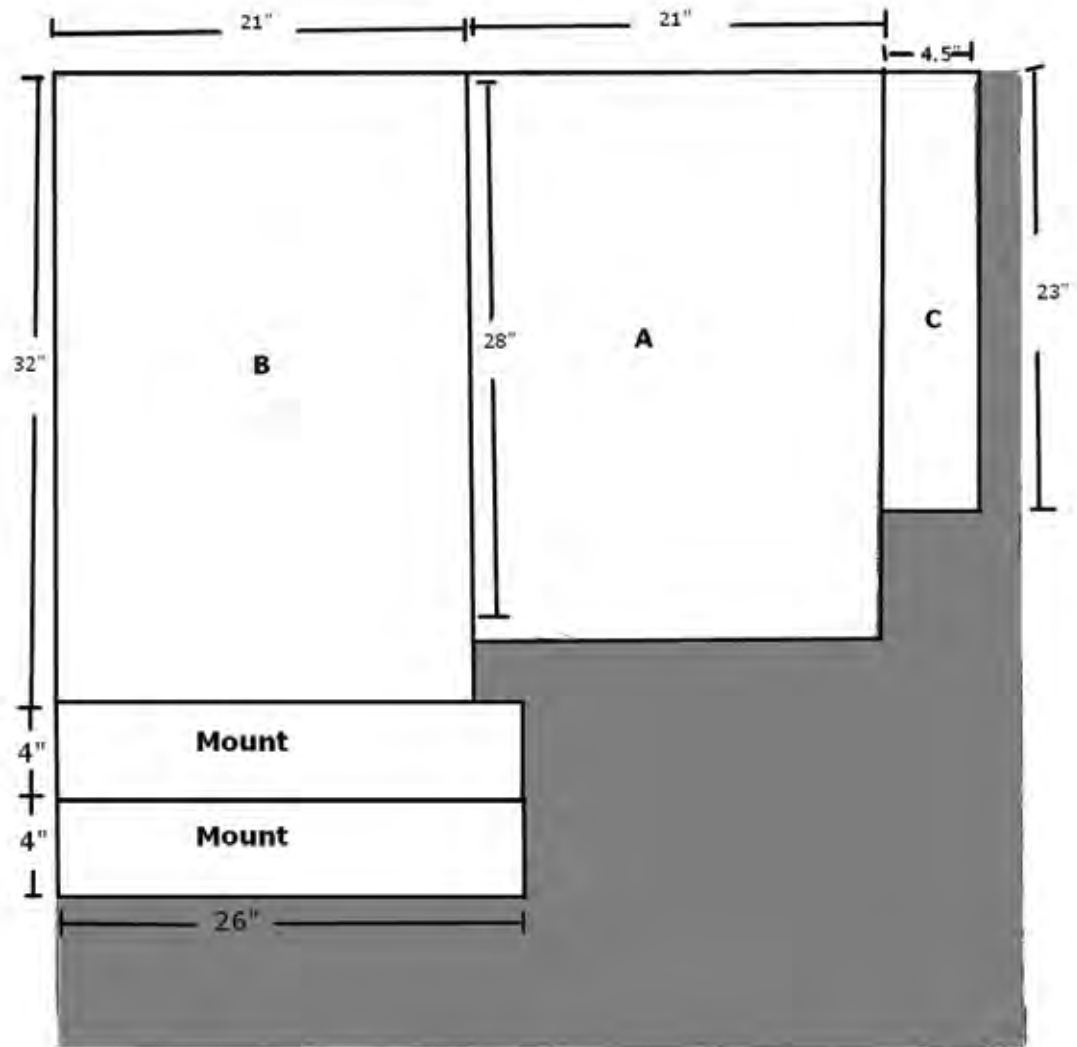

■ Unused Material

1" x 2" x 8' Pine Furring strip

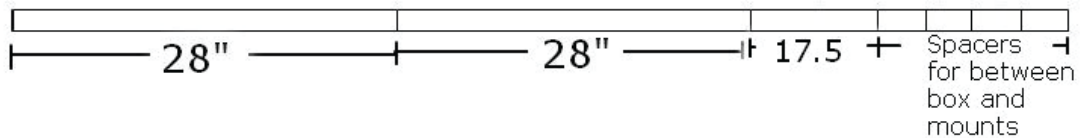

Building a Bat House

Bat Nursery House

Materials Needed (makes 2)

(See diagram)

½ sheet (4' x 4') ½" cdx (outdoor grade) plywood

½ sheet (4' x 4') 3/8" cdx (outdoor grade) plywood

Two pieces 1" x 6" (3/4" x 5 ½" finished) x 8' pine or cedar

One lb. 1 5/8" coated deck or exterior grade screws

20-25 1 ¼" coated deck or exterior grade screws

One quart black, water-based stain, exterior grade

One quart water-based primer, exterior grade

Two quarts flat water based paint or stain, exterior grade

One tube of paintable exterior grade caulk

Suggested Wood

We suggest using rough-sawn black locust, white oak, cedar or old barn wood because the bat house will last longer using these naturally decay-resistant materials

Optional materials

Black asphalt shingles

12-20 7/8" roofing nails

Recommended tools

Drill (1/8" for pilot holes)

Table saw

Drill bit

Paint brush

Caulk gun

Utility knife

Tape measure



Maternity box on right

Construction procedure

1. Measure and mark all wood as per cutting diagrams on pages 13-14. Cut out all parts.

2. In order to roughen interior and landing surfaces, score inside back wall (E), and partitions (G) with a utility knife or a sharp object. Space grooves ½" apart, cutting 1/16" to 1/32" deep.

3. Apply two coats of black, water-based stain to interior surfaces. Do not use paint, as it will fill grooves.

4. Screw back (E) to sides (2 Ds), caulking whenever wood meets wood. Drill pilot holes so the wood does not crack.

5. Drill pilot holes, caulk and use screws to attach 5" & 10" (I, J) spacers to inside corners as per drawings.

6. Place a partition on, to within a ½" of roof. Place 20" spacers (H) on partition (G), screw and caulk to first spacers (through partition). Be careful not to block the vents.

7. Repeat step 4 for remaining partitions (G) and spacers (H).

8. Caulk first and then screw front piece (B, C) to sides (Ds). Be sure top angles match (sand if necessary). Leave a ½" vent space between top and bottom front pieces. A bar clamp may be useful if sides have flared out during construction.

9. Attach roof supports (K) to the top inside of front (B) and back (E) pieces. Be careful that screws do not protrude into roosting chambers.

10. Caulk around all top surfaces, sanding first if necessary to ensure a good tight fit.

11. Screw roof (A) to side (D) and roof supports (K). Caulk all outside seams to properly seal roosting chamber.

12. Cut a line on underside of roof to act as a drip edge

13. Attach mounts to back of box, making sure there is ½-3/4" between box and mounts

14. Prime the exterior of the house.

15. Paint exterior with two coats. Be sure to use stain on the landing surface on back wall (E) and not paint as paint will fill the grooves.

Construction without Vent

1. Do not cut vent on side pieces (D)

Spacers on back wall will be one 20 inch piece (H) instead of one 10 inch (I) and one 5 inch (J).

Plans adapted from Bat Conservation International's Nursery House Design and discussions with Kent Borcharding

Building a Bat House

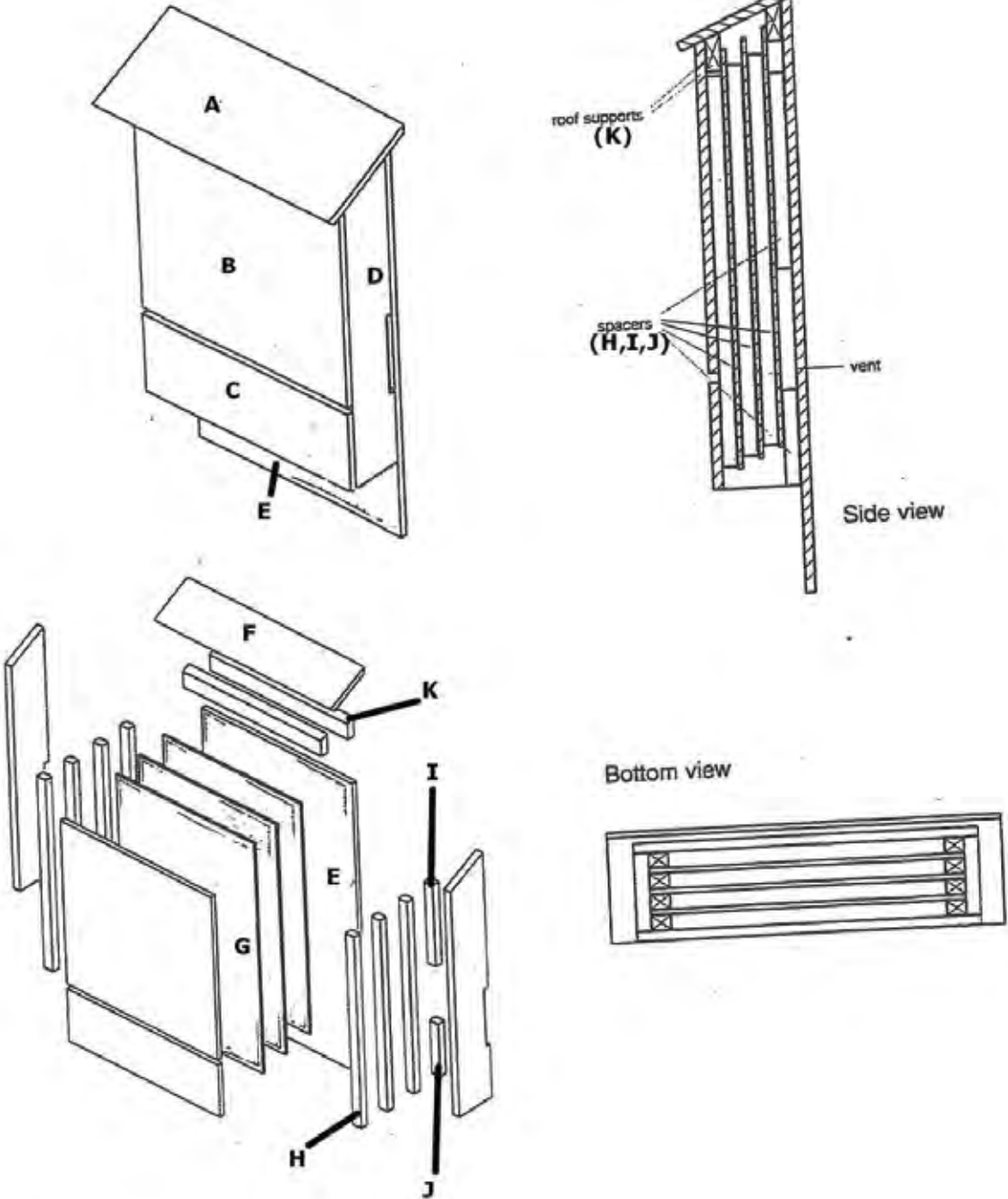

Building a Bat House

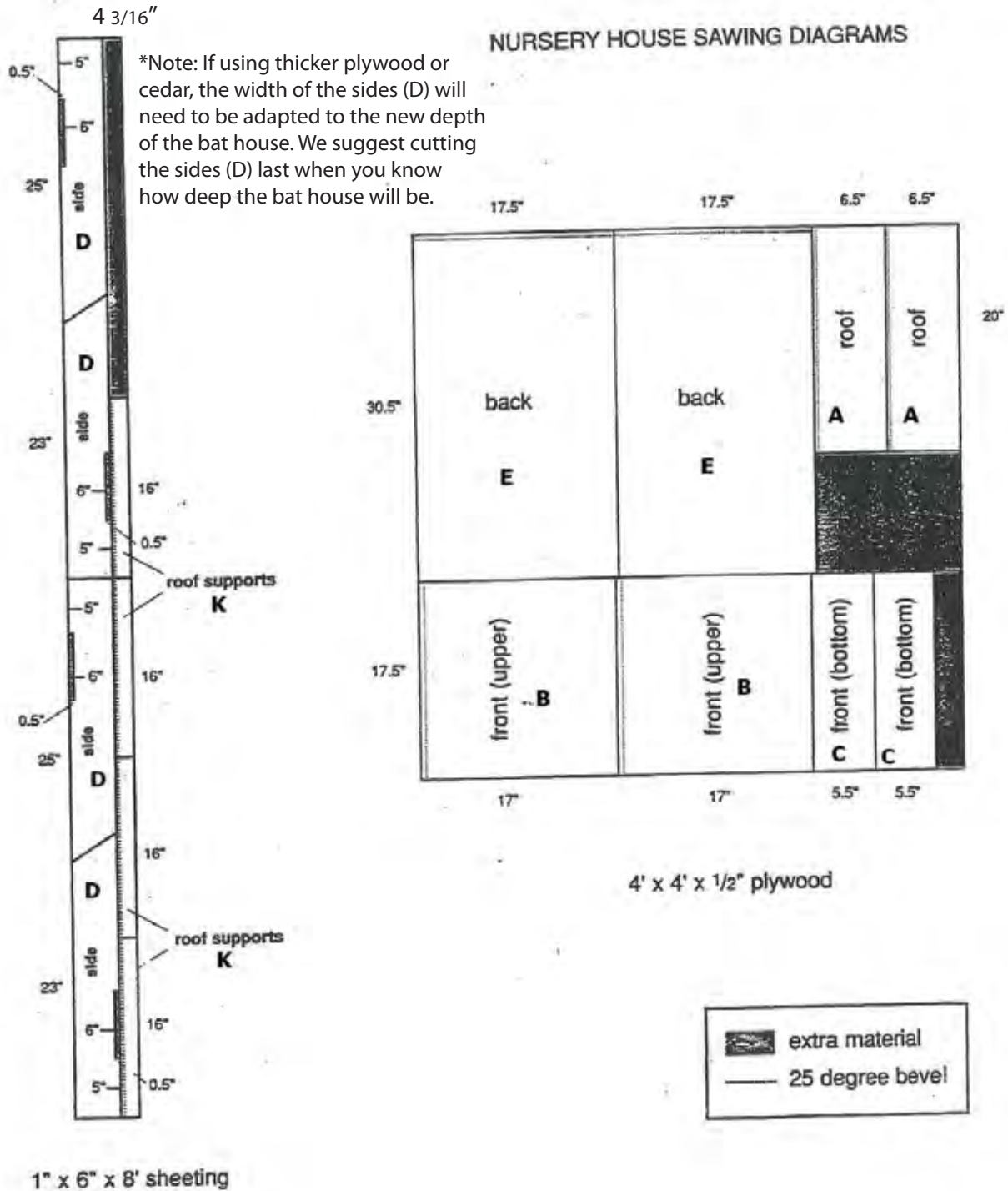

Building a Bat House

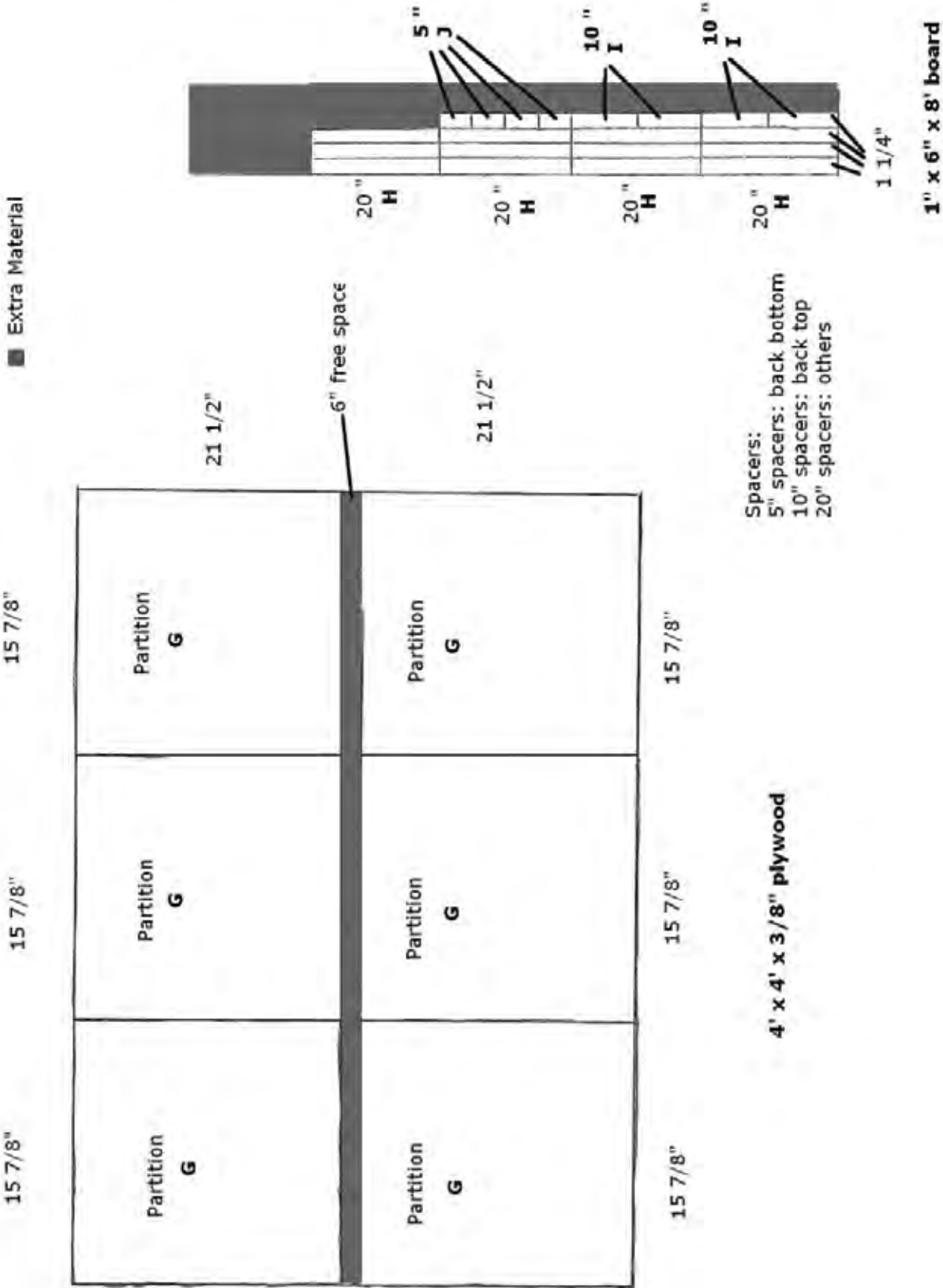

Building a Bat House

Bat nursery box back mounts

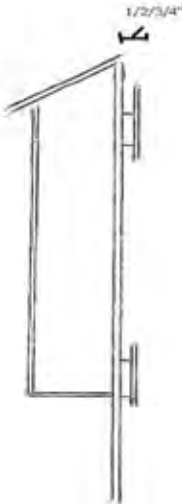
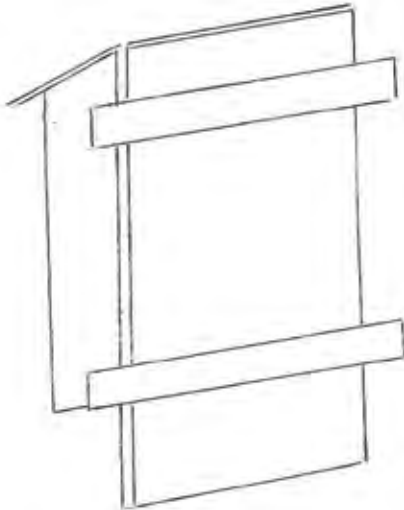

Building a Bat House

Rocket Box

Materials needed

12-16' of 4" x 4" rough cut post (if you can't get 12-16', use 4' of 4" x 4" and brace it to 2 pieces of 2" x 4" mounted together)

½" thick outdoor grade plywood

Exterior grade caulk

Exterior grade non-toxic, water-based black or brown paint

Water-based primer

Coated deck or exterior grade screws

Suggested Wood

We suggest using rough-sawed black locust, white oak, cedar or old barn wood because the bat house will last longer using these naturally decay-resistant materials

Recommended tools

Table saw and/or jig saw

Drill (1/8" size for pilot holes)

Phillips bit for drill

Measuring tape

Caulk gun

Paintbrush

Construction procedure

1. Measure, mark and cut all wood as per cutting diagrams
2. Cut angles on 4" x 4" post so bats have surface to roost on. We suggest 40° for top angle, and 60° angles into the post (the post is easier to manipulate and cut if it is shorter)
3. Screw ¾" spacers to 4 x 4 post
4. Drill one ¾" hole into one side for vent and attach screen so animals other than bats do not get in
5. Drill pilot holes so wood does not crack, and attach sides to each other and to wood post.
6. Drill pilot holes and attach roof boards with screws
7. Caulk all seams
8. Prime the exterior of the house
9. Paint exterior with two coats



Building a Bat House

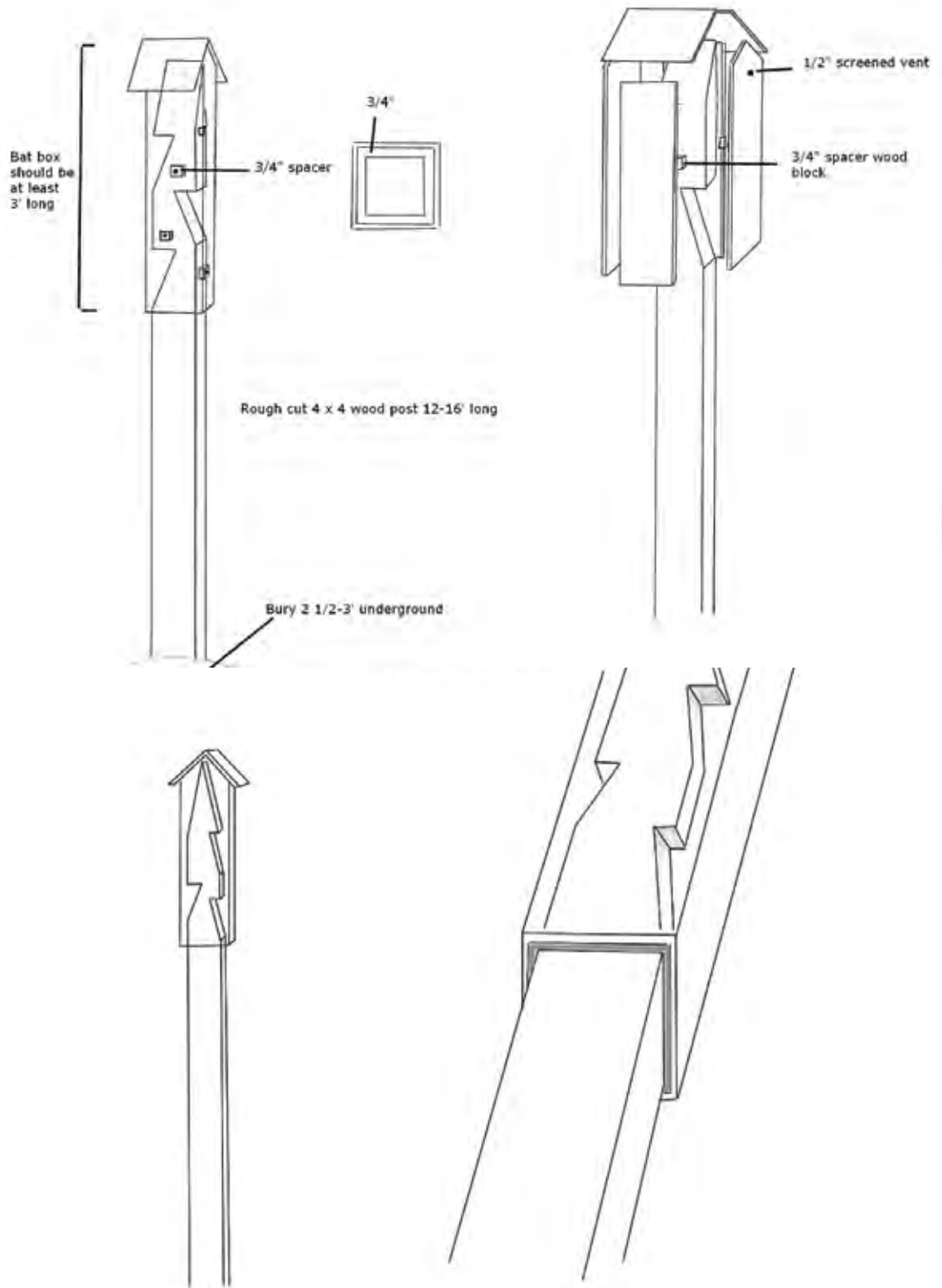

Building a Bat House



An alternative design for rocket boxes is spaced baffles emulating out from the central pole. The baffles mimic crevices found in square bat houses like the nursery box, but bats have the option to move around the pole seeking specific temperatures. Here, Kent Borcharding installed two-baffle rocket boxes above a series of nursery boxes in Lafayette County, WI. Image: K. Borcharding.

Building a Bat House



Little brown bats using a nursery box



Bat houses on the side of a building



Bat houses on a pole

Building a Bat House

Bat Houses

Looking to build and install a bat house to provide habitat for these beneficial pest-eaters? Here are a few tips to maximize the likelihood that you'll get bats in your new bat house!

Building

1. Make sure the bat house is well sealed. Bats don't like a drafty home. Use caulk on all the seams and screws.
2. Paint the box a dark brown or black to help the box heat up during the day and retain heat through the night.
3. Build the box wide and flat. Bats like to roost in tight places, so build the box so the inside has a 1/2 to 3/4 inch space for them to roost. Having multiple spaces, called baffles, will encourage a large colony.

Installation

1. Find a protected area that gets 6 or more hours of sun per day to help keep the bats warm.
2. Place the box on a pole or the side of a building, not on a tree. Trees tend to be too shady and bats are less likely to use those bat houses.
3. Mount the box 10-15 feet in the air facing east or south. Both directions will help get the morning sun.
4. Bats need water so it is best to place the box within 1/2 mile of a permanent water source.
5. Maintenance of the house should be minimal, but make sure there are no wasps in the baffles, and caulk any holes in the fall after the bats have left.



Yellowstone Lake State Park bat houses. Wisconsin DNR Bat Program



Little brown bats in a bat house. Kent Borchering



- *Once you get bats in your bat house, consider participating in the DNR's Bat Monitoring Program! More info can be found at <http://wiatri.net/inventory/bats>*

More information on bat houses can be found at <http://dnr.wi.gov> keyword <bats>

